

# Design and Construction of Monitoring and Control System in Swallow House Based on IoT

Al Dimas Sausan Roidoh<sup>1\*</sup>, Marto Sihombing<sup>2</sup>, Milli Alfhi Syari<sup>3</sup>

<sup>1, 2, 3</sup>STMIK Kaputama

[aldimas1111@gmail.com](mailto:aldimas1111@gmail.com)<sup>1\*</sup>, [martosihombing@yahoo.com](mailto:martosihombing@yahoo.com)<sup>2</sup>, [milli.fhisya@gmail.com](mailto:milli.fhisya@gmail.com)<sup>3</sup>

## Abstract

This study aims to design and build an Internet of Things (IoT) based monitoring and control system in a swiftlet building. Swiftlet nest farming is a rapidly growing industry in Indonesia, but still faces challenges in terms of monitoring and optimal environmental management for swiftlet productivity. The system developed integrates sensors to measure critical environmental parameters such as temperature. The research methodology includes hardware design using a microcontroller, sensors, and actuators connected to an IoT network. Software is developed to process sensor data, send it to blynk, and present information through a web interface that can be accessed remotely. This system is also equipped with an automatic control feature to keep environmental parameters within the optimal range. The results of the study show that the system is capable of real-time monitoring and providing notifications when an anomaly occurs. The automatic control feature successfully maintains temperature stability in the swiftlet building, where when the temperature read by the sensor is less than or equal to 25°C the lights will turn on and if the temperature is more than 29°C the lights will turn off. In conclusion, the implementation of this IoT-based monitoring and control system provides an effective solution to increase efficiency and productivity in swiftlet nest farming. This research opens up opportunities for further development in the application of IoT technology in the business sector, especially in swallow farming.

**Keywords:** *Internet of Things (IoT), monitoring system, automatic control, swiftlet cultivation, environmental sensors.*

## 1. Introduction

Currently, technological developments have been able to improve the quality and quantity of human life in various fields, such as automation in industry, agriculture, and cultivation. One example is monitoring the room temperature conditions in a swallow house, which can be done automatically or manually. A swallow house is a building structure specifically designed to support the cultivation of swallows, whose nests have high economic value. Environmental conditions in a swallow house must be arranged in such a way as to suit the biological needs of swallows, such as temperature, humidity, and lighting. This often requires the use of electrical equipment such as lights and water pumps.

Technological advances in the field of the Internet of Things (IoT) and sensors enable the development of more sophisticated and integrated monitoring systems. This system can provide real-time data on the condition of electrical equipment, enabling more effective control and management. The implementation of this technology in a swallow house can improve operational efficiency and provide the ability to perform predictive maintenance.

Manual management of electrical equipment in a swallow house is often inefficient and prone to human error. Without a good monitoring system, it is difficult to ensure that all equipment is functioning properly and optimally. Electrical equipment that continues to operate without proper control can cause energy waste and increase operational costs. Energy efficiency is very important to keep operational costs low and reduce the environmental impact of excessive electricity use. Undetected equipment damage can disrupt environmental conditions in the building, affect the health and productivity of swiftlets, and increase repair costs. Based on these problems, this study will Design and Build a Monitoring and Control System in an IoT-based swiftlet building. This system is expected to improve operational efficiency, reduce energy waste, and enable predictive maintenance, so that it can have a positive impact on the management of the swiftlet building.

## 2. Theoretical Basis

### 2.1. Design

Design is a series of procedures to translate the results of a system analysis into a programming language to describe in detail how the system components are implemented. The purpose of designing is to provide a clear and complete illustration to the programmers and engineers involved. Building is the activity of creating a new system or replacing and improving an existing system as a whole [1].

## 2.2. Monitoring System

The definition of system monitoring is the process of collecting data and analyzing the use of limited computer resources such as storage memory, central processing units, random access memory, graphic cards, virtual RAM, and various other computer resources. The monitoring process is needed to analyze whether computer resources are still suitable for use or require additional capacity [2].

## 2.3. Control System

A control system is a system of regulation or control over one or more quantities (variables, parameters) so that they are at a certain price or in a certain price range. A control system is a collection of ways or methods learned from human habits in working, where humans need an observation of the quality of what they have done so that it has the characteristics as expected at the beginning [3].

## 2.4. Swallow Building

The swallow nest building is made to resemble the natural habitat of swallows. Starting from the temperature, humidity, to the intensity of light inside the swallow nest building is made according to its natural habitat. Natural swallow nest management has many risks, ranging from the risk of accidents to the difficulty of controlling the swallow nest which is located far from where the swallow nest manager lives. To avoid the risks of natural swallow nest management, a swallow nest building is made. The purpose of this activity is so that the swallows can live comfortably in the building and can breed, until finally making a nest from their saliva [4].

## 2.5. Internet of Things

Internet of Things is an idea that aims to develop the function of internet connectivity that is connected continuously. The uses that are owned include data sharing, remote control, and so on, including objects in the real world [5].

## 2.6. NodeMCU ESP8266

NodeMCU is an open source IoT platform and also the firmware used uses the Lua scripting programming language. The term NodeMCU actually refers to the firmware used rather than the development kit hardware. NodeMCU can be likened to the Arduino board of the ESP8266. NodeMCU has combined the ESP8266 into a compact board with various functions like a microcontroller plus the ability to access Wifi and USB to Serial communication chips so that to program it only requires a micro USB data cable extension [6]. The following is an figure of NodeMCU:



Fig. 1: NodeMCU ESP8266

## 2.7. Relay

Relay is a mechanical switch that is controlled or controlled electronically (electromagnetic). The switch on the relay will change position from OFF to ON when electromagnetic energy is given to the relay armature. Relays basically consist of 2 main parts, namely mechanical switches and electromagnetic generator systems (iron core inductors) switches or relay contactors are controlled using the electrical voltage given to the inductor. Relays can be used to control AC motors with DC control circuits or other loads with different voltage sources between the control circuit voltage and the load voltage [7]. The following is a figure of a 2 channel Relay:



Fig. 2: Relay 2 Channel

## 2.8. Ultrasonic Sensor

Ultrasonic sensor is an ultrasonic sensor that can read a distance of approximately 2 cm to 4 meters. Ultrasonic sensor is a tool that can measure distances starting from 2cm to 4cm, with an accuracy value of up to 3mm. Ultrasonic sensor that functions to convert sound quantities into electrical quantities and vice versa. This ping sensor can detect the distance of an object by emitting ultrasonic waves with a frequency of 40 KHz and then detecting its reflection. This sensor can measure distances between 3 cm and 300 cm. The output from this sensor is in the form of a pulse whose width represents the distance. The pulse width varies from 115 us to 18.5 ms. Basically, the

PING sensor consists of a 40 KHz signal generator chip, an ultrasonic speaker and an ultrasonic microphone. The ultrasonic speaker will function as a converter of the 40 KHz signal into sound/voice quantities and the ultrasonic microphone will function to detect the reflection of its sound [8]. The following is a figure of an Ultrasonic Sensor:



**Fig. 3:** Ultrasonic Sensor

## 2.9. DHT11 Sensor

The DHT11 sensor is a sensor that can measure two environmental parameters at once, namely temperature and humidity. In this sensor there is an NTC (Negative Temperature Coefficient) type thermistor to measure temperature, a resistive type humidity sensor and an 8-bit microcontroller that processes both sensors and sends the results to the output pin in a single-wire bi-directional format or a single two-way cable [9]. The following is a figure of the DHT11 sensor:

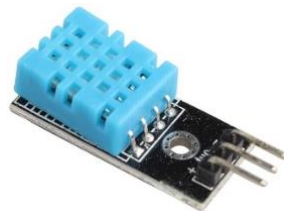

**Fig. 4:** DHT11 Sensor

## 2.10. Blynk

Blynk is not tied to a specific board or module. From this application platform, you can control everything remotely, anytime, anywhere. As long as it is connected to the Internet through a stable connection, that is what is called the Internet of Things (IoT) system [10]. The following is a display figure of the blynk software:



**Fig. 5:** Software Blynk

## 3. Analysis and Design

### 3.1. Research Methods

In this research, the method used in developing Internet of Things tools is the Prototype development method. The goal is to help system development to better understand what is being developed when the requirements specifications are not yet clear. This prototype development method also functions as a framework that explains how the research process takes place so that this research can be carried out in accordance with sequential stages.

Based on the methodology used in this research, the following research work method activities were formed:

1. Problem Identification  
Problem limitation and Problem formulation, this stage is the stage of identifying problems related to research, and limiting the scope of the problem or efforts to limit a scope in a problem that is too broad or wide so that a study can be more focused to be carried out, at this stage the problems related to a research object will be studied to be formulated so that the research can be carried out.
2. Data Collection  
Where at this stage data and information collection will be carried out using the Literature Study method to collect information related to the Monitoring and Control System in IOT based Swallow Buildings.
3. Communication

Communication between actors who will use the system to determine the overall target results of the software/system, identify the needs and environment in which the system will be used. At this stage, the communication carried out is by searching for related information, through book and journal references about problems in the electrical equipment monitoring system in the swallow building and then discussing it with experts or experts in the author's research field (discussions are carried out with the thesis supervisor) to analyze the problem further and conclude a solution that has been tested and the benefits of future research.

4. Prototype Design

Prototype Design, at this stage, the design will be carried out quickly and will represent all aspects in creating user needs, hardware needs, and software needs for the IoT based Electrical Equipment Monitoring System in Swallow Buildings.

5. Building a Prototype

This stage is the stage where we will design and build an IoT-based Electrical Equipment Monitoring System device in a Swallow Building according to what has been previously designed. When building a Prototype and Testing a Prototype, a system test is carried out based on Black Box Testing on the device that has been made so that it can be evaluated quickly.

6. Final Stage

Final stage where the design of the IoT-based Electrical Equipment Monitoring System for Swallow Buildings has been completed and made properly and correctly in accordance with the development phase and method used, namely the Prototype development method.

3.2. Flowchart

Making flowcharts is useful for making it easier to understand the work process of the tool. Flowcharts are used to visualize workflows or processes in automated systems. It helps in understanding the steps to be taken, decisions to be made, and how data or signals move through the system. Meanwhile, Blynk Flowchart allows users to control hardware via a mobile application.

This system flowchart describes the process of the control work system carried out by the microcontroller, starting from internet connection, initialization, sending data, to automatic or manual control of components to maintain temperature stability in the building. The flowchart from this research includes the tool automation system which can be seen in Figure 6:

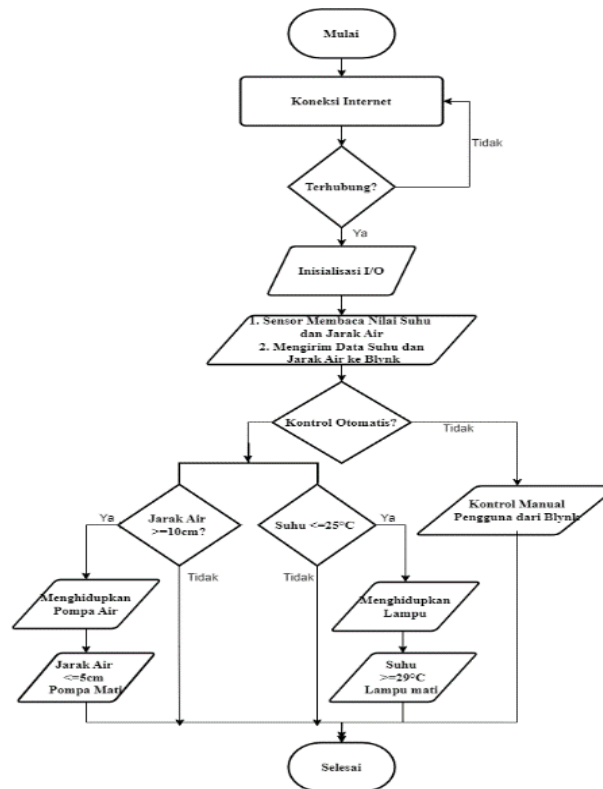

Fig. 6 : Flowchart

3.3. Block Diagram

This block diagram is a basic description of the system to be designed. Each part of the system block has its own function, by understanding the block diagram image, the designed system can be built well. The block diagram to be designed is as listed in Figure 7:

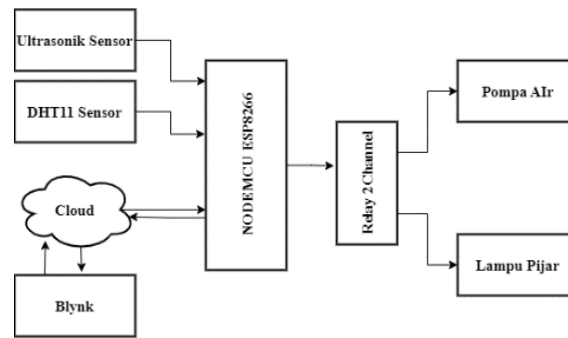

Fig. 7: Block Diagram

### 3.4. System Circuit Schematic

This circuit is composed of components needed to design the system so that the system can work as desired in the Monitoring and Control System in IoT-Based Swallow Buildings. The following circuit schematic can be seen in Figure 8:

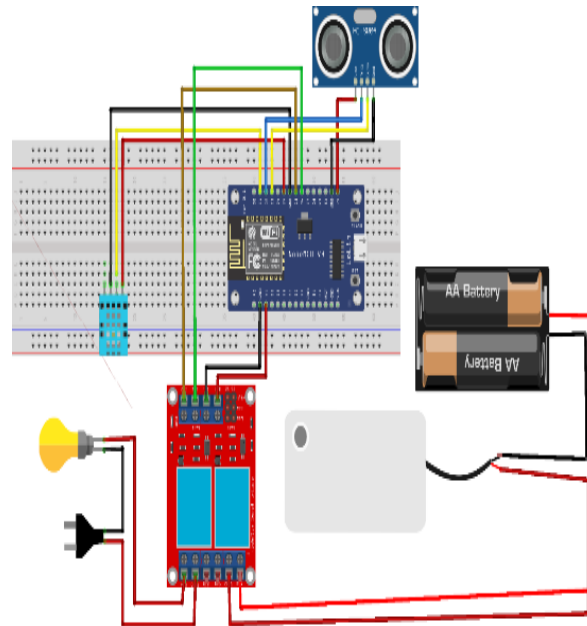

Fig. 8: System Circuit Schematic

## 4. Discussion and Implementation

This test was carried out by experimenting with an automatic control system through the DHT11 sensor by placing the sensor as close as possible to the fire and ice so that the temperature heats up and cools down. If the temperature received by the sensor is less than  $\leq 25^{\circ}\text{C}$ , the light will automatically turn on and if the temperature is more than  $\geq 29^{\circ}\text{C}$ , the light will turn off. And for automatic control of the water pump using a sensor from an ultrasonic sensor where if the sensor receives a water distance of  $\geq 10$  cm, the pump will turn on and if the water distance is  $\leq 5$  cm, the pump will automatically turn off.

To receive manual control, the blynk application requires an average time lag of 2 seconds to respond to commands. The time lag that occurs is because the internet connection used is unstable.

After all the completed circuits have been designed in "Design and Construction of Monitoring and Control Systems in IOT Based Swallow Buildings", then all the completed circuits are combined to form a miniature swallow building and a system prototype in such a way. The following is a figure of the design results that can be seen in Figure 9:

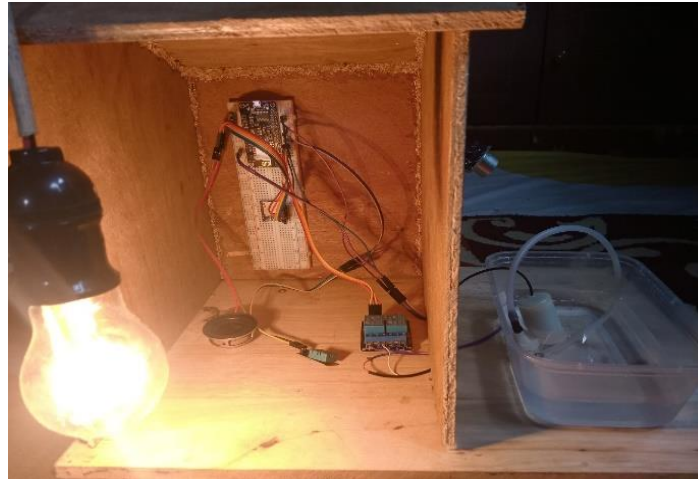

Fig. 9: View of the entire System Circuit

## 5. Conclusion and Suggestions

### 5.1. Conclusion

Based on the results of the design, testing and analysis that have been carried out as explained in the previous chapter, the conclusions drawn by the author are as follows:

1. With the existence of a remote monitoring system tool that can make it easier to find out the temperature conditions in the swiftlet building in real time.
2. With the existence of a monitoring and control system, it can be easily accessed by users via the blynk software using the NodeMCU ESP8266 as the main microcontroller.
3. With the existence of a system for automatic control that can regulate the temperature in the swiftlet building using the DHT11 sensor as a temperature detector controlled by the NodeMCU ESP8266.

### 5.2. Suggestions

The design and implementation of this tool are not free from shortcomings and weaknesses so that it requires the development of a better system. The suggestions that the author can convey include:

1. The need for development on the microcontroller, because the Arduino IDE microcontroller used in making this final assignment has a low RAM memory capacity so that the system runs slower
2. To make this system even better, it is necessary to add a system to carry out automatic control on monitoring temperature, humidity, light and pH measurements.
3. It is hoped that future development can be implemented with a wider network.

## References

- [1] A. H. Aini, Y. Saragih, and R. Hidayat, "Rancang Bangun Smart System Pada Kandang Ayam Menggunakan Mikrokontroler," *J. Teknol. Pertan. Gorontalo*, vol. 7, no. 1, pp. 27–35, 2022, doi: 10.30869/jtpg.v7i1.909.
- [2] A. Gracetantiono, "Implementasi Widgets Builder untuk Monitoring Kinerja Sistem Komputer dengan Menggunakan Rainmeter Alexander," *Angew. Chemie Int. Ed.* 6(11), 951–952., vol. 1, no. April, 2015.
- [3] R. Friadi and J. Junadhi, "Sistem Kontrol Intensitas Cahaya, Suhu dan Kelembaban Udara Pada Greenhouse Berbasis Raspberry PI," *J. Technopreneursh. Inf. Syst.*, vol. 2, no. 1, pp. 30–37, 2019, doi: 10.36085/jtis.v2i1.217.
- [4] Eny Susilowati, "Pengaturan Terhadap Pembangunan Gedung Sarang Burung Walet Di Kota Palangka Raya Provinsi Kalimantan Tengah," *Moral. J. Ilmu Huk.*, vol. 4, no. 1, 2018.
- [5] Tukadi, W. Widodo, M. Ruswiensari, and A. Qomar, "Monitoring Pemakaian Daya Listrik Secara Realtime Berbasis Internet Of Things," *Semin. Nas. Sains dan Teknol. Terap. VII 2019*, pp. 581–586, 2019, [Online]. Available: <https://ejurnal.itats.ac.id/sntekpan/article/download/659/468>
- [6] M. F. Pela and R. Pramudita, "Sistem Monitoring Penggunaan Daya Listrik Berbasis Internet of Things Pada Rumah Dengan Menggunakan Aplikasi Blynk," *Infotech J. Technol. Inf.*, vol. 7, no. 1, pp. 47–54, 2021, doi: 10.37365/jti.v7i1.106.
- [7] M. H. Abdullah, "Rancang Bangun Sistem Kontrol Lampu Listrik Menggunakan Remote Berbasis Mikrokontroler ATmega 8535," *J. Ilm. Ilk. - Ilmu Komput. Inform.*, vol. 2, no. 1, pp. 40–47, 2019, doi: 10.47324/ilkominfo.v2i1.19.
- [8] M. Amin, "Sistem Cerdas Kontrol Kran Air Menggunakan Mikrokontroler Arduino dan Sensor Ultrasonic," *J. Nas. Inform. Dan Teknol. Jar.*, vol. 4, no. 2, pp. 55–59, 2020.
- [9] Y. N. I. Fathulrohman and A. Saepuloh, "Alat Monitoring Suhu Dan Kelembaban Menggunakan Arduino Uno," *Jumantaka*, vol. 02, no. 1, p. 1, 2018, [Online]. Available: <https://jurnal.stmik-dci.ac.id/index.php/jumantaka/article/view/361>
- [10] R. Berlianti and Fibriyanti, "Perancangan Alat Pengontrolan Beban Listrik Satu Fasa Jarak Jauh Menggunakan Aplikasi Blynk Berbasis Arduino Mega," *Sain, Energi Teknol. Ind.*, vol. 5, no. 1, pp. 17–26, 2020.